

# DESIGN NOTES

## Ultralow Power Comparators Include Reference

Design Note 123

Robert Reay

With the explosion of battery-powered products has come the need for circuits that draw as little supply current as possible in order to extend battery life. Linear Technology's new family of micropower comparators with built-in references is designed to meet that need. Drawing only  $1\mu\text{A}$  of supply current per comparator, the LTC<sup>®</sup>1440–LTC1445 family provides the perfect solution to battery-powered system monitoring problems.

The LTC1440–LTC1445 family features  $1\mu\text{A}$  comparators, adjustable hysteresis, TTL/CMOS outputs that sink and source current and a  $1\mu\text{A}$  reference that can drive a bypass capacitor of up to  $0.01\mu\text{F}$  without oscillation. The parts operate from a 2V to 11V single supply or a  $\pm 1\text{V}$  to  $\pm 5\text{V}$  dual supply. Each comparator's input voltage range swings from the negative supply rail to within 1.3V of the positive supply. The comparator propagation delay is  $12\mu\text{s}$  with a 10mV overdrive, and the supply current glitches that commonly occur when comparators change logic states have been eliminated. Table 1 summarizes the features of each member of the family.

### Voltage Reference

The internal bandgap voltage reference has an output voltage of 1.182V above  $V^-$  for the LTC1440–LTC1443 and  $1.22\text{V} \pm 1\%$  for the LTC1444 and LTC1445. The reference output is capable of sourcing up to  $200\mu\text{A}$  and sinking  $15\mu\text{A}$ . The reference output can directly drive an external bypass capacitor up to  $0.01\mu\text{F}$  without oscillation. By placing a resistor in series with the bypass capacitor, ringing at the

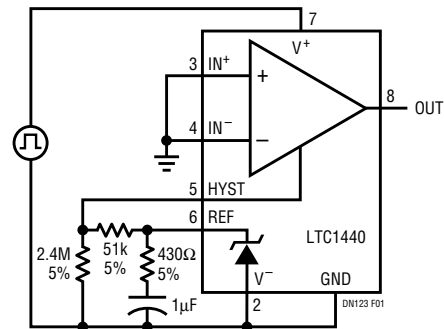

Test Circuit

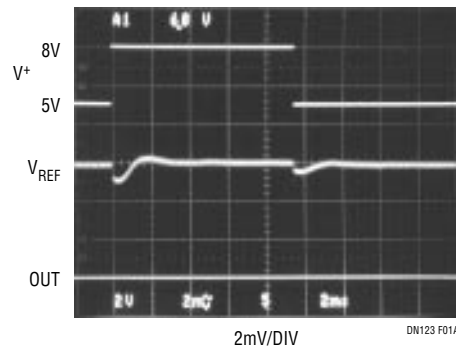

Figure 1. Reference Settling

reference output can be eliminated and a greater capacitance value can be used. The bypass capacitor prevents reference load transients or power supply glitches from

⚡ LTC and LT are registered trademarks of Linear Technology Corporation.

Table 1.

PART NUMBER	NUMBER OF COMPARATORS	SUPPLY	SUPPLY CURRENT	ADJUSTABLE HYSTERESIS	REFERENCE	COMPARATOR OUTPUT
LTC1440	1	Dual	$2.5\mu\text{A}$	Yes	$1.182\text{V} \pm 1\%$	CMOS
LTC1441	2	Single	$3.5\mu\text{A}$	No	$1.182\text{V} \pm 1\%$	CMOS
LTC1442	2	Single	$3.5\mu\text{A}$	Yes	$1.182\text{V} \pm 1\%$	CMOS
LTC1443	4	Dual	$5.0\mu\text{A}$	No	$1.182\text{V} \pm 1\%$	CMOS
LTC1444	4	Single	$5.0\mu\text{A}$	Yes	$1.221\text{V} \pm 1\%$	Open Drain
LTC1445	4	Single	$5.0\mu\text{A}$	Yes	$1.221\text{V} \pm 1\%$	CMOS

disturbing the reference voltage, which helps eliminate false triggering of the comparators when they are connected to the reference. Figure 1 shows the reference voltage settling during a power supply transient.

### Undervoltage/Overvoltage Detector

The LTC1442 can be easily configured as an undervoltage and overvoltage detector as shown in Figure 2. R1, R2 and R3 form a resistive divider from  $V_{CC}$  so that comparator A goes low when  $V_{CC}$  drops below 4.5V, and comparator B goes low when  $V_{CC}$  rises above 5.5V. A 10mV hysteresis band is set by R4 and R5 to prevent oscillations near the trip points.

### Single Cell Lithium-Ion Battery Supply

Figure 3 shows a single cell lithium-ion battery to 5V supply with the low-battery warning, low-battery shutdown and reset functions provided by the LTC1444. The LT<sup>®</sup>1300 micropower step-up DC/DC converter boosts the battery voltage to 5V using L1 and D1. Capacitors C2 and C3 provide input and output filtering.

The voltage monitoring circuitry takes advantage of the LTC1444's open-drain outputs and low supply voltage operation. Comparators A and B, along with R1, R2 and R3, monitor the battery voltage. When the battery voltage drops below 2.6V, comparator A's output pulls low to generate a nonmaskable interrupt to the microprocessor to warn of a low-battery condition. To protect the battery from

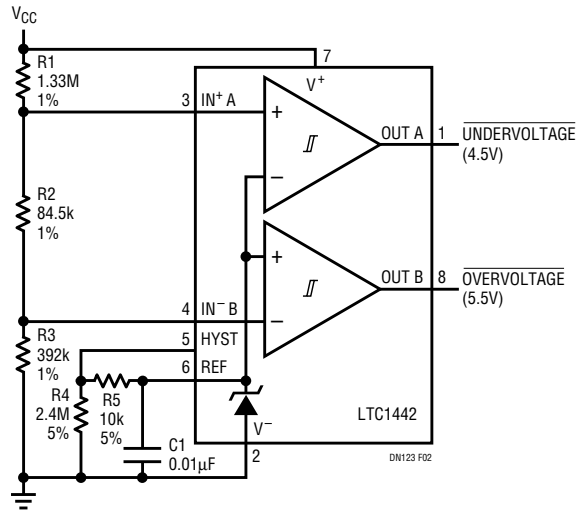

Figure 2. Undervoltage/Overvoltage Detector

overdischarge, the output of comparator B is pulled high by R7 when the battery voltage falls below 2.4V. P-channel Q1 and the LT1300 are turned off, dropping the quiescent current to 20 $\mu$ A. Q1 is needed to prevent the load circuitry from discharging the battery through L1 and D1.

Comparators C and D provide the reset input to the microprocessor. As soon as the boost converter output rises above the 4.65V threshold set by R8 and R9, comparator C turns off and R10 starts to charge C4. After 200ms, comparator D turns off and the Reset pin is pulled high by R12.

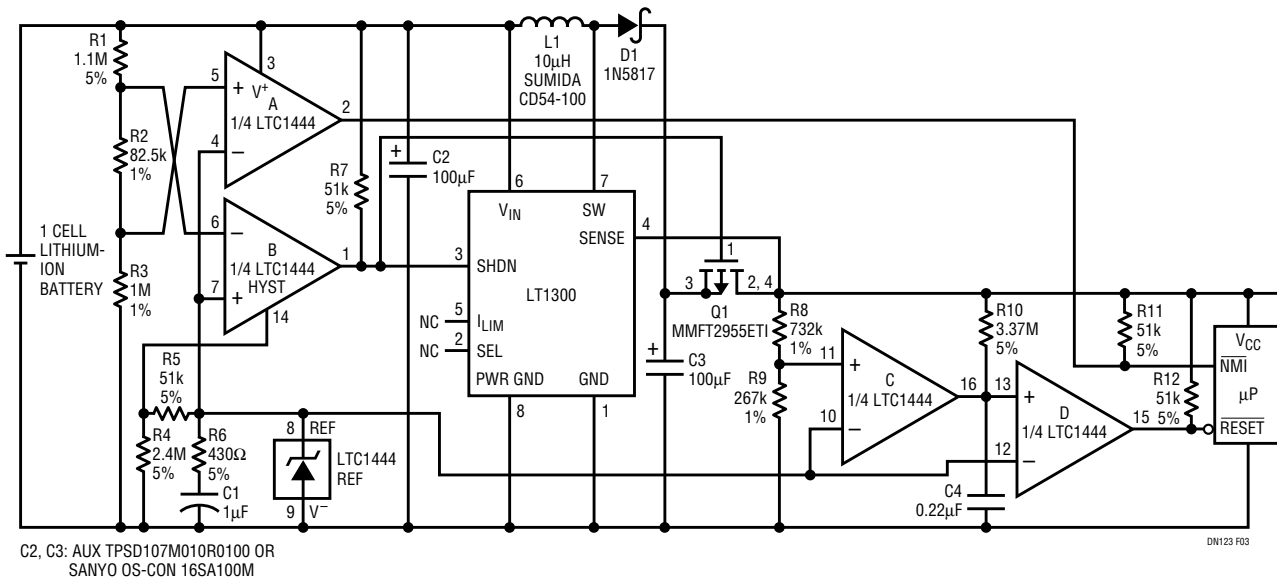

Figure 3. Single Cell to 5V Supply

For literature on our Comparators, call **1-800-4-LINEAR**. For applications help, call (408) 432-1900, Ext. 456